

Robonaut: A Robotic Astronaut Assistant

M.A. Diftler
Lockheed Martin
Automation and Robotics Department
Mail Code C35
Houston, TX 77058
diftler@jsc.nasa.gov

R.O. Ambrose
NASA Johnson Space Center
Automation, Robotics and Simulation Division
Mail Code ER4
Houston Texas 77058
rambrose@ems.jsc.nasa.gov

Keywords Humanoids, dexterous robots, anthropomorphic, space manipulator, redundant system, mechatronics.

Abstract

NASA's latest anthropomorphic robot, Robonaut, has reached a milestone in its capability. This highly dexterous robot, designed to assist astronauts in space, is now performing complex tasks at the Johnson Space Center that could previously only be carried out by humans. With 43 degrees of freedom, Robonaut is the first humanoid built for space and incorporates technology advances in dexterous hands, modular manipulators, lightweight materials, and telepresence control systems. Robonaut is human size, has a three degree of freedom (DOF) articulated waist, and two seven DOF arms, giving it an impressive work space for interacting with its environment. Its two five fingered hands allow manipulation of a wide range of tools. A pan/tilt head with multiple stereo camera systems provides data for both teleoperators and computer vision systems.

1 Introduction

The requirements for extra-vehicular activity (EVA) on-board the International Space Station (ISS) are expected to be considerable. These maintenance and construction activities are expensive and hazardous. Astronauts must prepare extensively before they may leave the relative safety of the space station, including pre-breathing at space suit air pressure for up to 4 hours.

Once outside, the crew person must be extremely cautious to prevent damage to the suit.

Certain pieces of the Space Station Alpha have been designed to be serviced by robotic systems. The Canadian Space Agency's Special Purpose Dexterous Manipulator (SPDM) was developed for this purpose. To be serviceable by the SPDM, worksites have been designed to have different approach corridors than EVA and specialized interfaces.

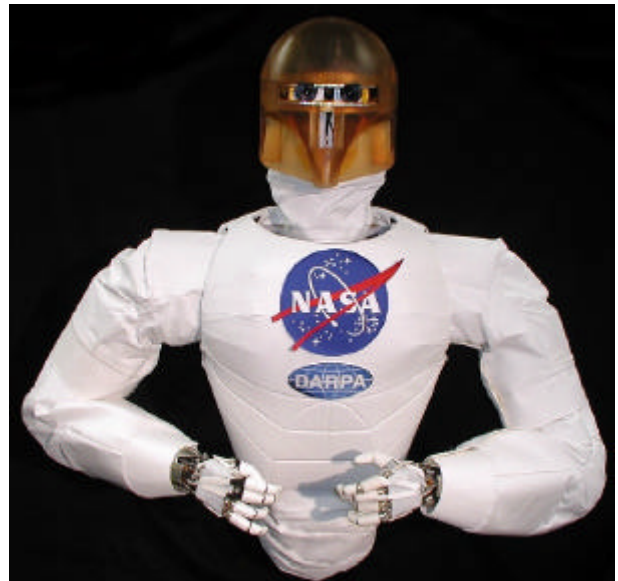

Figure 1. Robonaut

While specialized worksites for robotics systems have been very successful in a variety of industries, including space, the Robotic Systems Technology Branch at the NASA Johnson Space Center (JSC) is taking a different

approach to building service robots for space; developing robots to work with existing human interfaces. This is Robonaut's niche in the international space manipulator family. It can work in the same corridors as the crew, use a significant subset of the EVA tool set, and is designed to work alongside a crew person safely. Additionally, Robonaut can serve as a minuteman, providing mission controllers with a highly dexterous device for dealing with an EVA emergency in far less time than the several hours it takes to prepare an astronaut for a space walk.

2 Robonaut System Overview

The focus of the Robonaut team has been in the design and construction a dexterous upper extremity. However, Robonaut has recently transitioned from a single hand and arm with a fixed shoulder to a dual limbed upper body with an articulating three degree-of-freedom (DOF) waist. This results in a total of 43 DOF dexterous robot (figure 1).

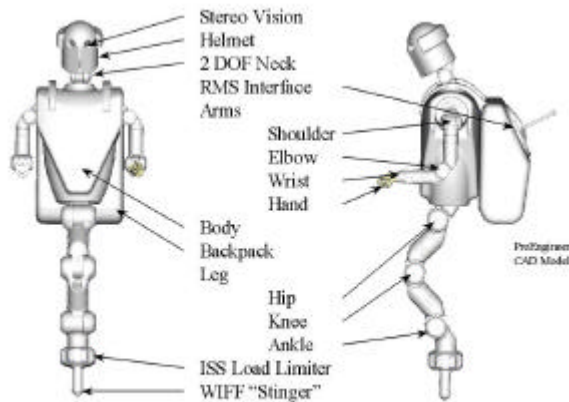

Figure 2. Robonaut in Zero-G Configuration

While working during EVA, crew members typically place both legs into a portable foot restraint. In its space configuration, Robonaut uses the same interface with a single seven DOF leg. The end effector of this leg uses the same interface as the crew's foot restraints and plugs into sockets around Space Station. Having a leg provides Robonaut with the ability to anchor itself at worksites and provides a great amount of body mobility once anchored. Figure 2 shows a representation of Robonaut in its space configuration.

Beyond having the correct anatomy to work with EVA equipment, the Robonaut system is designed with space operations in mind. During the design phase, the ability to work in space was considered for nearly every aspect, including materials selection, thermal endurance, lubricants, avionics, and computer selection.

Robonaut is currently a teleoperated system. The anthropomorphic form of Robonaut allows a very intuitive mapping between human and robot. By incrementally augmenting the teleoperation capabilities, the goal is to lighten the teleoperator's load by transitioning to a more supervisory role.



Figure 3. The Robonaut Hand

3 Hands

Robonaut's hands set it apart from any previous space manipulator system. These hands can fit into all the same places currently designed for an astronaut's gloved hand. A key feature of the hand is its palm degree of freedom that allows Robonaut to cup a tool and line up its long axis with the roll degree of freedom of the forearm, thereby, permitting tool use in tight spaces with minimum arm motion. Each hand assembly shown in figure 3 has a total of 14 DOFs, and consists of a forearm, a two DOF wrist, and a twelve DOF hand complete with position, velocity, and force sensors. The forearm, which measures four inches in diameter at its base and is approximately eight inches long, houses all fourteen motors, the motor control and power electronics, and all of the wiring for the hand. An exploded view of this assembly is given in figure 4. Joint travel for the wrist pitch and yaw is designed to meet or exceed that of a human hand in a pressurized glove.

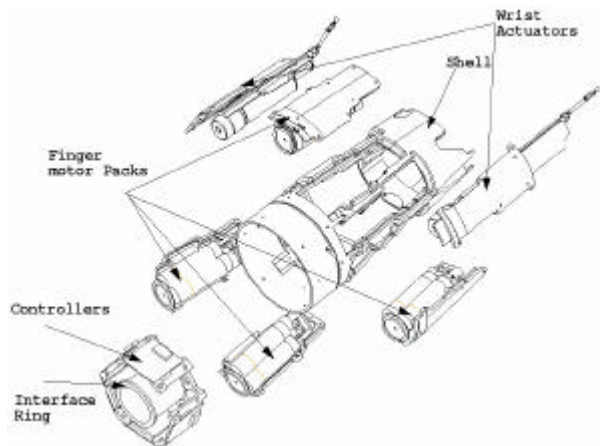

Figure 4: Forearm Assembly

The requirements for interacting with planned space station EVA crew interfaces and tools provided the starting point for the Robonaut Hand design [1]. Both power and dexterous grasps are required for manipulating EVA crew tools. Certain tools require single or multiple finger actuation while being firmly grasped. A maximum force of 20 lbs and torque of 30 in-lbs are required to remove and install EVA orbital replaceable units (ORUs) [2].

The hand itself consists of two sections (figure 5) : a dexterous work set used for manipulation, and a grasping set which allows the hand to maintain a stable grasp while manipulating or actuating a given object. This is an essential feature for tool use [3]. The dexterous set consists of two 3 DOF fingers (index and middle) and a 3 DOF opposable thumb. The grasping set consists of two, single DOF fingers (ring and pinkie) and a palm DOF. All of the fingers are shock mounted into the palm.

In order to match the size of an astronaut's gloved hand, the motors are mounted outside the hand, and mechanical power is transmitted through a flexible drive train. Past hand designs [4,5] have used tendon drives which utilize complex pulley systems or sheathes, both of which pose serious wear and reliability problems when used in the EVA space environment. To avoid the problems associated with tendons, the hand uses flex shafts to transmit power from the motors in the forearm to the fingers. The rotary motion of the flex shafts is converted to linear motion in the hand using small modular

leadscrew assemblies. The result is a compact yet rugged drive train.

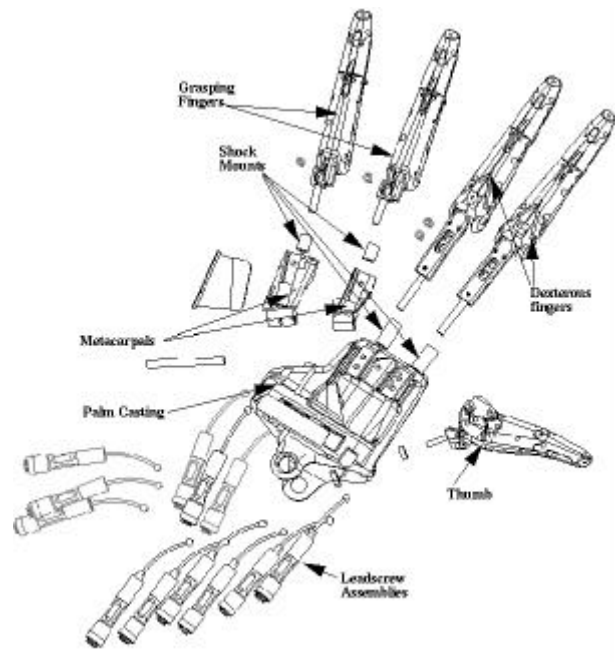

Figure 5: Hand Anatomy

Overall the hand is equipped with forty-two sensors (not including tactile sensing). Each joint is equipped with embedded absolute position sensors and each motor is equipped with incremental encoders. Each of the leadscrew assemblies as well as the wrist ball joint links are instrumented as load cells to provide force feedback.

In addition to providing standard impedance control, hand force control algorithms take advantage of the non-backdriveable finger drive train to minimize motor power requirements once a desired grasp force is achieved. Hand primitives in the form of pre-planned trajectories are available to minimize operator workload when performing repeated tasks.

4 Arms, Neck and Waist

Robonaut's arms, neck and waist are human scale manipulators designed to fit within EVA corridors. Beyond its volume design, these appendages have human equivalent strength, human scale reach, thermal endurance to match an eight hour EVA, fine motion, high

bandwidth dynamic response, redundancy, safety, and a range of motion that exceeds that of a human limb. Both the arms and waist have a dense packaging of joints and avionics developed with the mechatronics philosophy. The endoskeletal design of the arm and waist house thermal vacuum rated motors, harmonic drives, fail-safe brakes and 16 sensors in each joint. The arm's small size, 1:1 strength to weight ratio, density, and thermal vacuum capabilities make it the state-of-the-art in space manipulators today (figure 6).



Figure 6: Robonaut Arm

Robonaut has four serial chains emerging from the body: two upper arms for dexterous work, a neck for pointing the head, and a leg for stabilizing the body in micro gravity. These chains are all built with common technology, best described as a family of modular joints, characterized by size and kinematic motion type. There are three torque ranges, from 10 ft-lbs to 200 ft-lbs, and two motions types, roll and pitch. Other scales have been built for thermal vacuum testing, but are not included in the currently integrated system.

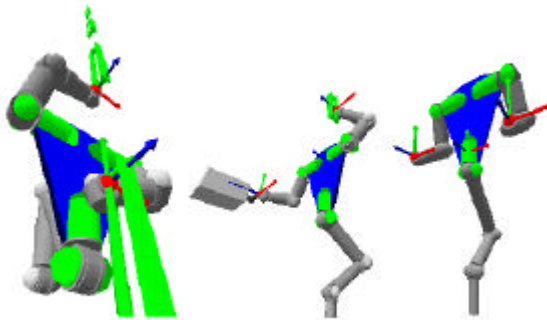

Figure 7. Arm Design Visualization Tool

A software design tool, with visualization shown in Figure 7, was developed at JSC for use in trade studies of kinematic arrangements [6], strength [7] and thermal analyses [8]. Using a database of drive train components, optimized sizing of the manipulator joints was achieved with identification of thermal endurance [9] and task workspace suitability [10]. Of particular interest is the choice of a bifurcating system, where a central, and articulated chain, here the segment from ankle to body, splits into two independent upper arms. This waist mobility has been shown to complement the dexterity of a dual arm system, by allowing the intersection of the two arm's dexterous workspaces to be repositioned around a work site. This enables the use of smaller, closely configured arms to perform dexterous manipulation over a large resultant workspace. Figure 8 shows the coordination of a waist bending motion with an arm's reach, expanding the arm's reachable workspace. The intersection of the arm's dexterous region is a toroidal space centered on the line of action passing through the two shoulders, which is then in turn swept by the waist motion for a spherical dexterous workspace of the full system, shown schematically in Figure 9.

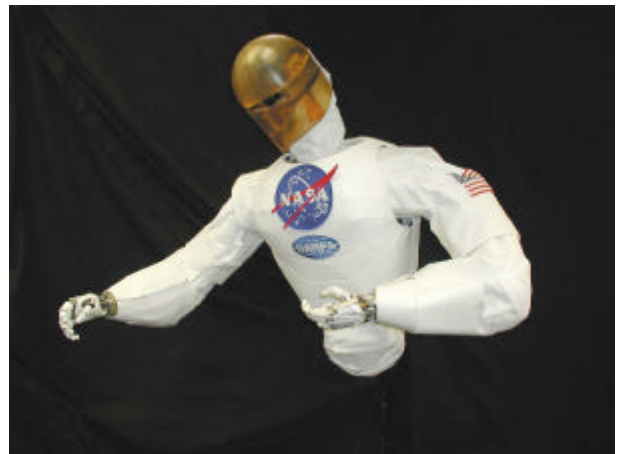

Figure 8: Workspace with Waist Motion

The common joints that make up the waist, arms and neck use a torque based control law at the lowest level taking advantage of embedded strain gauges. Better than a 20HZ bandwidth is available at this level. Higher level position loops wrap around the torque controller to provide impedance control at the joint level.

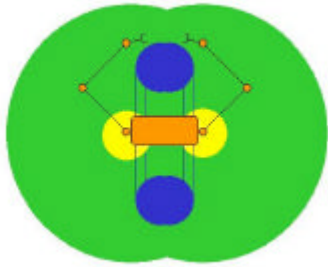

Figure 9. Dexterous Workspace of Robonaut Arms with Waist Motion

The torque control includes feedforward compensation to reduce the impact of inertial, damping and friction forces internal to both the motor and load sides of the joint mechanism. The command to control the torque at the joint strain gauge, T_{Scmd} , combines the desired output torque and load dynamics.

$$T_{Scmd} = T_{Des} + J_L \ddot{q}_L + b_L \dot{q}_L + F_L \quad (1)$$

This command is then divided by the gear ratio and added to the predicted motor inertial losses to yield a motor level torque command:

$$T_{Mcmd} = \frac{T_{Scmd}}{N} + J_M \ddot{q}_M + b_M \dot{q}_M + F_M \quad (2)$$

Both the low and high speed compensations are modeled identically and are shown in figure 10.

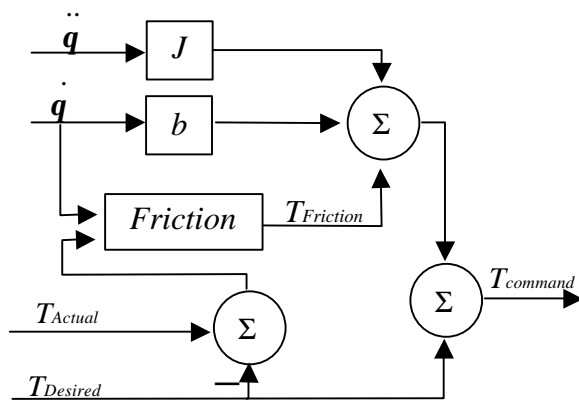

Figure 10: Feed Forward Block Diagram

The parameters needed for the feed forward algorithms are collected from mechanical specifications and through a variety of system identification techniques.

At the Cartesian level arm algorithms incorporate gravity compensation and model following techniques to minimize feedback errors and ensure excellent tracking. Arm force control algorithms take advantage of both shoulder and forearm six axis force/torque sensors to provide impedance control. The head and waist controllers employ similar techniques. As with the hands, arm primitives are available to minimize operator work load when performing repeated tasks.

5 Mobility

Robonaut's inherent versatility has motivated several future design configurations. Beyond the single leg option for space based operations, other options seen in figure 11, include rovers with the Robonaut upper body configured as a Centaur for surface missions, a rail mounted version confined spaces, and even a two legged Robonaut for terrain applications. The upper body has a back pack configuration to connect directly with the large Space station manipulators for gross positioning and a version with extra battery storage capability for independent mobility.

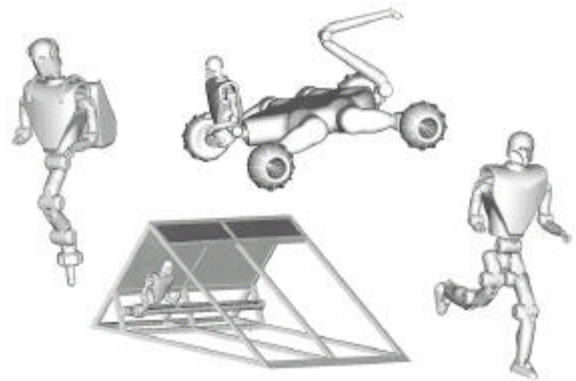

Figure11: Mobility Options

6 Brainstem

The Robonaut control system design philosophy is inspired by the human brain anatomy. The human brain embeds some functions, such as gaits, reactive reflexes and sensing, at a very low level, in the spinal cord or nerves [11]. Higher functions, such as cognition and planning take place in other parts of the brain.

Within the Robonaut control system, the functions analogous to the very low level functions in the brain are referred to as the brainstem. The brainstem contains the joint and Cartesian controllers for the 43 DOF, sensing, safety functions, and low level sequencing.

Using the brainstem approach allows higher level functions to operate independently of the low level functions. This allows the Robonaut system to implement a variety of control methods ranging from teleoperation to full autonomy with the brainstem unaware of which higher level control system is being used. An application programmer's interface (API) separates the brainstem from the higher level systems. This standard interface allows systems to both monitor and modify the state of the Robonaut brainstem.

As a humanoid robot designed for the purpose of working with humans in space, safety is the central to Robonaut's control system. By embedding safety systems at a low level in the brainstem overall safety and performance are improved [12].

The computing environment for Robonaut utilizes the PowerPC processor. This processor was selected for both performance and its heritage in space flight. The processor's and I/O connect across a VME bus and use the VxWorks™ real-time operating system. Robonaut's brainstem software is written using the Controlshell™ development environment. Controlshell provides a graphical interface that enforces object-oriented design and the re-use of code. The flexibility and performance of these systems make for an exceptional controls development environment.

7 Operational Modes

Currently, Robonaut's primary mode of operation is through a telepresence control system. As shown in figure 12, when wearing the Virtual Reality gloves, and a helmet, an operator's hands, arms and neck are mapped directly to the Robonaut system. Sensors in the gloves determine the operator's hand position, creating a command for the Robonaut hand. The neck, arm and waist commands are generated using six-axis Polhemus sensors mounted to the operator's helmet, wrist and chest, respectively. The scale and proportions of the Robonaut

anatomy are very human like, allowing for the use of everyday experience, instincts and training to be applied to teleoperated tasks. Novice operators are able to demonstrate proficiency with less than five minutes of immersion.



Figure 12: Telepresence Control Gear

More shared control, leading to enhanced autonomy for Robonaut is in work. The hand and arm primitives noted above are the building blocks that are being used to add the first automatic modes into Robonaut's control system. The API allows both in-house and external artificial intelligence developers to integrate task planners, vision based grasping systems, and learning algorithms. The goal is to give Robonaut's supervisor a combination of autonomous and telepresence control modes to accomplish complex tasks.

8 Task Experiments

In its current teleoperation mode, Robonaut can perform a wide variety of space, surface and, tool usage tasks. Space tasks include tether hooks used as lifelines by astronauts during EVA and power drills representing torque tools. Surface tasks include scooping gravel and transferring it into containers. Robonaut also can work with a wide variety of tools, including wire strippers, socket wrenches, and flashlights.

Adding a second arm/hand and waist has added another dimension to Robonaut's capabilities. Instead of being forced to be handed tools by a human in a very limited

range, Robonaut is now capable of picking up tools at one area and re-positioning its waist to operate at the worksite. The addition of the second arm and hand allows for Robonaut to perform two handed tasks. For example, Robonaut has worked with EVA hand rails, connected network cables, and worked with soft goods boxes. Robonaut performing two handed tasks are shown in figures 13 and 14.

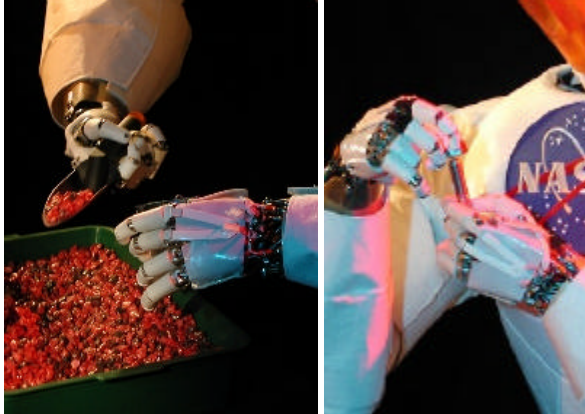

Figure 13. Robonaut Manipulating Simulated Martian Gravel(L) and Threading a Nut onto a Bolt(R).

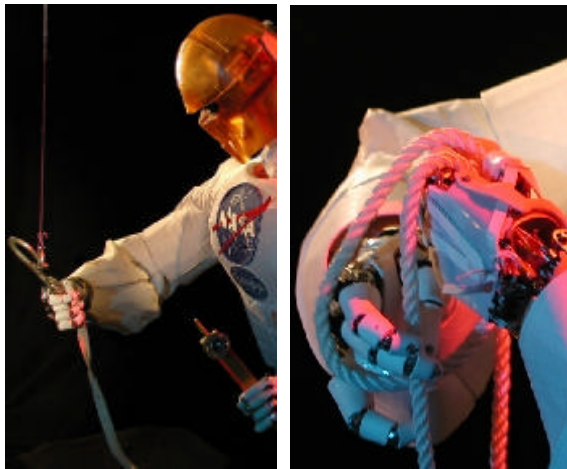

Figure 14: Robonaut Attaching a Tether Hook(L) and Tying a Knot in a Rope(R).

9 Conclusions and Future Challenges

Robonaut subsystems development is an ongoing process. Arm and hand designs are continuing to push the state of the art in packaging, strength, and sensor count. Avionics are becoming smaller and better integrated leading to a true mechatronic design. The teleoperation

interface is becoming even more intuitive for the operator, enabling more complex tasks. The common denominator for these technologies is the upper body dexterous system, which continues to be the team's development focus. Having started with this portion of the humanoid system, we continue to advance its dexterity while seeking specific lower body options optimized for new missions.

References

- [1] Lovchik, C.S., and Diftler, M. A., "The Robonaut Hand: a Dexterous Robot Hand for Space", *Proceedings of the IEEE International Conference on Robotics and Automation*, Detroit, Michigan, 907-912, 1999.
- [2] Extravehicular Activity (EVA) Hardware Generic Design Requirements Document, *JSC 26626*, NASA/Johnson Space Center, Houston, Texas, July, 1994.
- [3] Jau, B., Dexterous Tele-manipulation with Four Fingered Hand System. *Proceedings of the IEEE International Conference on Robotics and Automation*, Nagoya, Japan, 338-343, 1995.
- [4] Jacobsen, S., *et al.*, Design of the Utah/M.I.T. Dexterous Hand. *Proceedings of the IEEE International Conference on Robotics and Automation*, San Francisco, CA, 1520-1532, 1986.
- [5] Salisbury, J. K., & Mason, M. T., *Robot Hands and the Mechanics of Manipulation*. MIT Press, Cambridge, MA, 1985.
- [6] Ambrose, Robert O., "Interactive Robot Joint Design, Analysis and Prototyping", *IEEE 95 Robotics and Automation Conference*, Nagoya, Japan, May 1995.
- [7] Ambrose, Robert O., Diftler, M. A., "The Minimum Form of Strength in Serial, Parallel and Bifurcated Manipulators", *IEEE Robotics and Automation Conference*, Leuven Belgium, 1998.
- [8] Ambrose, Robert O. and Berka, R. B., "Thermal Management in Hyper-Redundant Space Manipulators", *SPIE Cooperative Intelligent Robotics in Space IV*, September 1993.
- [9] Ambrose, Robert O. and Tesar, D., "The Optimal Selection of Robot Modules for Space Manipulators", *Space '94*, Albuquerque NM, February, 1994.

- [10] Ambrose, R.O. and Diftler, M.A., "Definitions of Strength in Serial and Bifurcated Manipulators", *ISA Conference*, November 1996, Chicago Il.
- [11] Albus, J., A Theory of Cerebellar Function. *Mathematical Biosciences*, 10 (1971) 25-61
- [12] Aldridge, H., Bluethmann, W., Ambrose, R., Diftler, M., Control Architecture for the Robonaut Space Humanoid, *Proceedings, Humanoids 2000, The 1st IEEE-RAS Conference on Humanoid Robots*, Cambridge, MA 2000.