

# A METHODOLOGY FOR ELECTROMECHANICAL EVALUATION OF MULTIFUNCTIONAL INTERCONNECTS FOR ON-ORBIT SERVICING DEMONSTRATION

Mehmed Yüksel\*, Marko Jankovic, Wiebke Brinkmann, Jona Saffer, and Christian Schoo

*DFKI GmbH, Robotics Innovation Center, Robert-Hooke-Str.1 28359 Bremen, Germany,  
name.surname@dfki.de*

## ABSTRACT

Multifunctional interconnects, which allow to connect different (modular) robotic components mechanically as well as to ensure electrical and data transfer, do not yet exist as standardized components in European spaceflight. However, multifunctional interconnects already exist and were evaluated in a benchmark as part of the PERIOD project. The goal of the benchmark was to compare the data and power transmission as well as docking capabilities of these interconnects and also to design future testing standards. The benchmark is divided into mechanical and electrical test sections. This paper focuses on the test methodology for the electrical tests as well as describes an ontology for collecting, distributing, and reusing the results.

Key words: orbital; interface; evolution; electrical test; data transmission, test method; ontology, knowledge representation.

## 1. INTRODUCTION

There are various approaches to reduce space debris. One approach is the use of reusable and exchangeable modules, which can be used in orbit to be coupled with each other so that, for example, a satellite can be built. The satellite can then be extended again and again with further functions by coupling further modules, or in the case of failures the corresponding modules can be exchanged. In order to be able to couple or exchange modules flexibly with one another, so-called multifunctional interconnects can be used. In European space robotics, there are some multifunctional interconnects developed specifically for such application, which will be declared as so-called Standard Interconnects (SIs) in the long run. In the PERASPERA In-Orbit Demonstration (PERIOD) project, three of these SIs were

tested for their function and features as part of an SI benchmarking.

The design of an SI contains mechanical, electrical and software components. As the intersection of these three domains, the first task of the interface is to mechanically connect two sides of different systems or subsystems [1]. The second task is to transmit power and data after a successful mechanical coupling. If necessary, the possibility of thermal transmission might also be required.

The selection of an appropriate SI is not only critical for assembly and operation, but also for the design of crucial equipment, such as, e.g. a manipulator, which affects its development effort and cost. This paper provides an overview of the methodology developed for benchmark purposes in the electrical domain to test and distinguish between three SIs, HOT-DOCK from Space Applications Services, Belgium [2], iSSI@ from iBOSS GmbH, Germany [3] and SIROM from SENER Aerospace, Spain [4] (also see Fig. 1).

Furthermore, it gives an introduction about the project goal and the needed benchmark test. It also describes the developed ontology to evaluate and distribute the benchmark tests, as well as performed tests and test method evolution. Finally, the critical analysis outlines the obtained results as well as the inferred classification using the mentioned ontology. The paper concludes with a conclusion and future work.

## 2. PROJECT PERIOD

The PERIOD project is one of the operational grants (OGs) of the third phase of the European Union's Horizon 2020 Space Strategic Research Cluster on Space Robotics Technologies with an objective to increase the maturity of space technologies and prepare them for an in-orbit demonstration, planned within the 2023-2027 time frame. Specifically, the project will build upon the work of previous OGs

\*Corresponding author.

Email address: [mehmed.yueksel@dfki.de](mailto:mehmed.yueksel@dfki.de) (Mehmed Yüksel)



Figure 1: The used SIs with their adapters from left to right: iSSI® active and passive with optional formfits, HOTDOCK active and passive and SIROM active and passive. The passive SIs are in the front row

to raise the technology readiness level of core technologies and define an orbital demonstration concept for on-orbit servicing and assembly. The specific objectives of the project are:

- (a) Definition of a demonstrator concept based on an orbital factory, integrated on the Bartolomeo platform of the International Space Station, to manufacture and operate a spacecraft in-orbit.
- (b) Further development of core space robotics software components up to the Technology Readiness Level (TRL) 5.
- (c) Evaluation of the current state-of-the-art standard interfaces in a benchmark scenario.
- (d) Evaluation of all the core components for assembly on a breadboard.
- (e) Implementation of communication and dissemination activities to inform the space community and potential customers on the capabilities of on-orbit servicing and assembly, as well as provide transparency on risks and mitigations.

The PERIOD<sup>1</sup> Consortium is proposing a very ambitious demonstration scenario and Factory concept. A satellite will be manufactured in an Orbital Factory and injected in LEO (Low Earth Orbit) for operations. The manufacturing includes the fabrication of an antenna, the assembly of the satellite components and its reconfiguration and inspection in the Factory [5, 6]. In this context, so-called cubesats are to be used as modules, which are connected to each other via an SI in order to build the required objects. These modules are connected to each other with the help of a manipulator arm. For this purpose, the manipulator arm also has a multifunctional interconnect as an end effector and in this way can grip the modules, which are also equipped with a multifunctional interface. For this purpose, the three multifunctional interconnects, HOTDOCK, iSSI® and SIROM were tested in order to find the suitable one for the in-orbit demonstration scenario.

<sup>1</sup><https://period-h2020.eu/>

The focus of one of the activities of German Center for Artificial Intelligence (DFKI) at Robotics Innovation Center (RIC) within the project is to provide a method to distinguish between different SIs (see in Fig. 1) as well as document the strengths and weaknesses of current versions of SIs.

Tests were performed by DFKI as an independent body to evaluate the performance of the SIs in relevant demonstration scenarios and in full transparency to the Consortium members. This will lead to a recommendation of a preferred interface to be considered during the B2 phase of the project [7]

The necessity to perform a benchmark of the mentioned SIs lies in the current nonexistence of a standard defining a set of features and/or performances that the same SIs will need to comply with in order to be considered for an in-orbit factory. A TRL might be used for this purpose as it is able to capture a maturity of a technology at a given point in time and for a given operational environment. However, to perform a technology readiness assessment (TRA), a fixed set of performance requirements and definition of the operational environment is required which are outside of the scope of the current project deliverables. Moreover, a TRA is not meant to be used as a method to further develop technologies. On the contrary the SI benchmark as one of its outcomes is to provide valuable feedback to the SI manufacturer needed to further improve their interfaces for usage in the in-orbit robotic factory within the PERIOD demonstration scenario.

The benchmark was performed in two main areas, the electrical and the mechanical domain, as illustrated in Fig. 2.

### 3. DEVELOPMENT OF THE TEST METHODOLOGY TO EVALUATE THE SIs FOR ELECTRICAL ASPECTS

The *period electrical test* aims to analyse the application-oriented functioning of SIs, focusing on electrical aspects for data and power transmission.

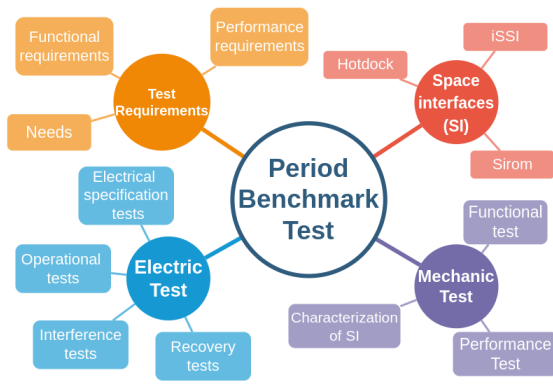

Figure 2: The principal structure of period benchmark test

The test cases and the functional system requirements in electrical domain are described with in the frame of the PERIOD project.

The test methodology is split into four test steps each with an incremental level of difficulty ranging from functional tests to performance tests to evaluate the specifications of the interfaces in question. The first step was the tested for functionality of system and control of the SI functions. This is followed by testing of the physical-electrical properties. Then the test interface is tested for data transmission under possible sources of interference from other data buses or power lines. The final test evaluates functionality under worst-case conditions such as a momentary power failure or data bus failure.

### 3.1. Operational test (Test A)

To perform the SI evolution steps with test interfaces, both passive and active sides must first be coupled electromechanically. Here, the active interface plays the primary role, receiving the control commands and executing the docking and locking motion. Therefore, testing begins with the active interface and verification of its functions and capabilities. For this purpose, the test setup of the SI must be established with the supplied control software/CAN bus commands transceiver on the test computer in order to be able to control the coupling, power and data transmission. During this step, the test interface is put into operation and the necessary functions (e. g. functionality in symmetry, measurement of bus resistance, bus connectivity after the coupling,...) of it are tested to ensure that the further steps can be realized.

### 3.2. Electrical Specification Test (Test B)

This test approaches to bring out the primary characteristics of the SI such as electrical contact charac-

teristics after coupling. To capture the capabilities of the SI two perspectives for communication channels and power lines are considered during the analysis of the system's contact properties. (a) The power-line test aims to find out the validation and measurement of the power transmission through the power bus according to the specifications and the requirements of the SI. In addition, the energy losses and the voltage drop at the interface after the coupling are recorded, and the thermal development through the power transmission is observed. (b)The data lines (Controller Area Network (CAN) + Ethernet) are tested to analyze the data transfer capability for each line independently, with measurement of the maximum data transfer rate.

### 3.3. Interference Test (Test C)

To determine whether mutual interference occurs due to the design of the interface, this series of experiments investigated the interference effects of data and power lines operating in parallel. (a) First, the power line was used as the interference source and various electrical loads (power resistor and variable current and pulse-width modulation (pwm) signal via BLDC motor) were generated on the power line causing interference on the adjacent data lines for CAN or Ethernet. In this step, the data lines were recorded individually. Therefore, it is expected that the data bus (CAN or Ethernet) will be disturbed by the adjacent bus for the power line if there is a design problem in the interface. (b) Another point was that the mutual interference of the data lines must be considered. Different bus speeds and different data loads are generated on the data lines, causing interference on the adjacent CAN or Ethernet data line. Therefore, it is expected that the data bus (CAN or Ethernet) will be disturbed by the adjacent bus for the other data line if there is a design problem in the interface.

### 3.4. Recovery Test (Test D)

The recovery test aims to provide some realistic recovery cases with the SIs that may occur during the critical operating condition such as coupling/uncoupling or in the coupled state due to problems with the electrical system or the control data. The SIs needs to be able to start in an undetermined state, recognize its current state, and continue operation without further problems, malfunctions, or damage. This test aims to observe the functionality of the interfaces for loss of CAN control communication and power supply interruption at three critical moments of the SI's, (a) coupling state(s), (b) coupled state(s), (c) decoupling state(s).

#### 4. PERFORMANCE OF THE BENCHMARK ELECTRIC TESTS

Tests are performed in a laboratory having in mind a practical application selected from a robotics domain for three SIs according in four test steps mentioned in the previous section.

An adjustable laboratory power supply is used to set different voltage and current ranges(see in Table 1). A 4-channel oscilloscope with current probe amplifier with current probes and several multimeters are used as measuring instruments. A test PC with 1 Gbit/s Ethernet interface and CAN bus is utilized for data bus testing and logging. An R/I/P adjustable electrical load with max 150W, wound power resistors for 100-600W are applied for consumption. A modified Brushless DC electric motor (BLDC) motor and a DFKI developed controller as a noise generator to produce current peaks were also used for current load tests. With the help of a thermal imaging camera, we checked the thermal evolution after the transmission of the test current. Depending on the test type, we used different test setups depending on the test perspective. An example of a test setup is the illustrated as test circuit for the electrical interference test (Test C) in Fig. 3.

For the benchmark test, the requirements and experience-based test ranges were determined for in power and data bus, which were summarized in the Table 1. For the power bus test as a minimum configuration, the interfaces were tested according to the power criteria of 3.5A at 36V. For the load test, we tested the SIs as a common test criteria for 15A at 28V and for the interference test up to 23A (peak). In addition to these usual ranges of the benchmark, some other test values are used for further tests after the respective test SI, which are referred to as spec in the table. These spec-related values have not been published due to the confidentiality of the data.

The power bus test results are captured with the oscilloscope. The Ethernet bus was tested and logged with iperf<sup>2</sup> to determine the bandwidth and bus speed. The test data was analyzed for different data transfer conditions using an open source application<sup>3</sup> modified according to the benchmark purpose. The CAN test program based on can-utils from Debian was used to analyze the CAN bus, generating various CAN packets for different off speeds and bus loads and logging test results and analyzing this data. The thermal development is recorded and evaluated by the commercial software provided with this camera.

<sup>2</sup><https://iperf.fr/>

<sup>3</sup><https://github.com/hchiuzhuo/iperfPlotter>

#### 5. TEST RESULTS MANAGEMENT AND EVOLUTION

The evaluation of the results is based on the individual test protocols of each tested interface. To compare SIs, we rank them using the benchmark test metric, which includes 12 evaluation criteria derived from Knowledge-based Open Robot voCubulary as Utility Toolkit (korcut)<sup>4</sup> ontology. Using a four-point rating scale (1 poor, 4 best), the values of these 12 criteria were compared with the test results. The first eight criteria, *maturity, operability, (software) compatibility, reliable design and robustness, energy consumption, telemetry, transmission by rotational symmetry, recoverability (resilience, prevention and robustness to external disturbance)*, are evaluated directly after each criterion. The other four criteria, *data transmission CAN, data transmission LAN, power transmission, thermal development*, that widely differed for SIs were calculated separately for requirement [75%] and specification [25%] of each criterion and summarized cumulatively. The sum of the scores of these 12 criteria distinguishes SIs in terms of their electrical design and performance characteristics.

##### 5.1. Need to use an ontology in PERIOD project and on-orbit servicing purposes

The necessities of the ontology in the context of the PERIOD project can be summarized in following four main points. (a) The PERIOD project, like other robot development projects, has the common character of having an interdisciplinary and intercultural background involving different fields of interest and work. The goal of the project stands on a joint development of a benchmark and a Standard Interconnect concept with the help of different vendors with their solutions. Not only that each interface (HOTDOCK, iSSI® and SIROM) has its own specific characteristics that are not directly comparable and can play an important role depending on the application, but also the terminology between vendors can vary in individual cases, which is quite normal for such cases. A common reference readable by humans and machines that stores such terms or criteria and allows them to be shared is helpful. (b) A common model representing the interconnection of the requirements, needs or the specifications of the SI can take the role here of uniformly representing a generic model for the mechatronic level of an interface that can be used for further tasks (e.g.control of robots). (c) The tests performed,

<sup>4</sup>korcut is a collection of expert knowledge as ontologies with a focus on domain construction and mechatronic robot design [8] as well as a collection of Python library based on Owlready[9] and the add-on gives the developer knowledge support in the form of rules, relations, or meta-models from the ontology family and enables ontology-driven robot design.



## Test C1

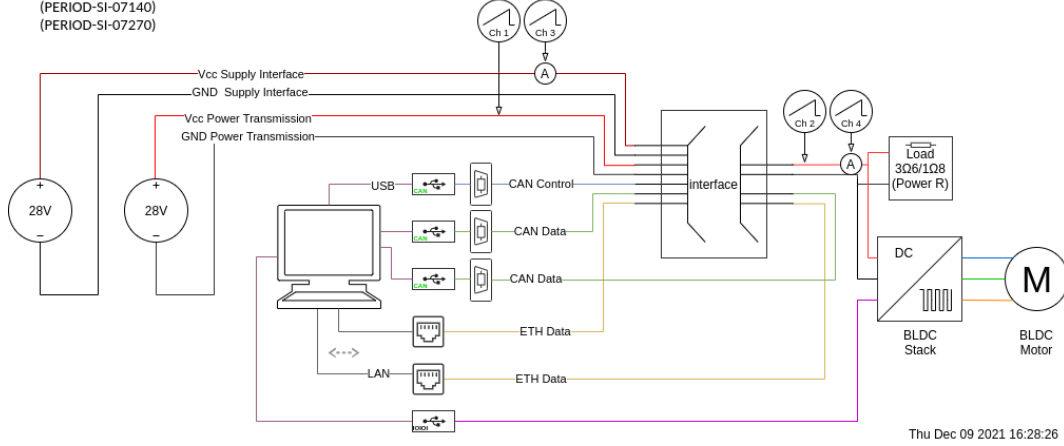

Figure 3: The test circuit of electrical interference tests (Test C).

Power Bus Test		Ethernet Bus Test		CAN Bus Test	
Test Voltage	Test Current	Target Ethernet Speed	Number of simultaneous connections	CAN Bus bitrate	Delay between packages
36V	3.5A	1 Mbit/s	1	1 Mbit/s	200ms
28V	15A	10 Mbit/s	5	800 Kbit/s	100ms
28V	15-23A <sup>*</sup>	100 Mbit/s	10	500 Kbit/s	50ms
Spec. <sup>†</sup>	Spec. <sup>†</sup>	1000 Mbit/s	25	250 Kbit/s	10ms
		max speed <sup>‡</sup>	50	125 Kbit/s	5ms
				20 Kbit/s	1ms

Table 1: Test parameters of benchmark electric and data tests for SIs.

(\*) The variable current value used during the interference test.

(†) The other test values correspond to the specification of the respective SI

(‡) No forced speed is specified, instead the maximum speed is attempted to be determined

both electrical and mechanical, have rich test results that need to be represented in a unified and rich way to allow dynamic interrogation or traceability for variable use case requirements. (d) Not only the test method involves variations because of the distinction of SI, both the results vary extremely for some cases. Therefore, direct linkage to the test method used or other parameters as well as information may be important to accurately analyze interface specifications and capabilities on a task-specific basis.

## 5.2. Development of *Period Ontology*

The ontology plays the key role in collecting all the results of the tests in a standard, structured and machine-interpretable way such that they can be later used with ease to generate new knowledge from the existing one, e. g. which interface is better suited for certain application based on specific requirements or needs. This way not only a decision making process can be made more traceable and transparent but also if possible it can enable its usage in other domains not originally foreseen by its devel-

opers, such as the active debris removal domain[10] or the ground segment.

In order to develop an ontology, it is crucial to have a methodology. For the development of korcut and as well as its sub domain ontology the *period ontology*, we used the methodology oriented to the Noy et al. [11] and Nicola et al. [12] works. *Period ontology* is covering the interface domains, with electrical perspectives for data and power transmission properties as well as additional mechanical properties, to define a interface for widely usable robotic domain from mobility[13] to space. The *period ontology* is developed to getting following competency questions.

- What are the electrical properties of the benchmark SI model?
- What are the coupling states of the interface?
- Can a specific interface transmit power / data with certain values?
- What misalignment capabilities has a particular interface?

Some examples of vocabulary used to develop *period ontology* are: Standard Interconnect, coupling state, coupled state, decoupling state, homing, latching, ready to capture (RTC), capture range, envelope, TRL, electronics capability, supply range, data transfer type, data transfer range, power transfer range.

As part of the korcut ontology family, the *Period ontology* aims to represent SI ontological, both as a model of SI with properties and as test data to be collected to enable a rich body of knowledge, with the goal of further use in other applications. The ontology developed for this purpose consists of explicit or implicit defined classes with properties, which are used to sort individuals and is depicted in Fig. 4. This figure shows an overview of the *Protege* environment[14] and the developed *period ontology*. This figure presents an example<sup>5</sup> of a restricted class (e.g. *Test\_Requirement\_2*), which is a defined class and groups constraints together as a bundle of related requirements. After reasoning, this class receives the suitable SIs that satisfy the given constraint(e.g.*test\_interface\_2*). The user can get an explanation about this classification, why it was classified so implicitly (see in the figure on the lower tab). Using such modeled classes allows comparison of tested SIs from different perspectives, depending on the mission scenario. A meta-model that generically represents SI and contains all the necessary parameters from the specifications, functional and performance properties of the benchmark has been implemented in *Period ontology*.

### 5.3. Period Ontology workflow

The major challenge in the application of ontology, both in the proper development of the ontology from a domain and ontological perspective, and its integration in the process, is that this added value of knowledge representation and powerful reasoning capability is realized. korcut provides a library based on *Python* and using the *Owlready API* to access these domain ontologies and provide corresponding functionalities such as classification, query or necessary background functions such as conversion, computation. In this work, the workflow for integrating benchmark test results was extended by using a standardized test protocol and automatic modeling of test objects. Thus, a tested SI can be imported based on the values recorded in this electrical test protocol file. This information is used to automatically generate the model of tested SI in *Period ontology* according to the benchmark criteria, which speed up the import process. The data col-

<sup>5</sup>In this example, due to confidentiality concerns, fictitious test values (e.g. Ethernet speeds) are used as test results to validate the functionality of the ontology and the resulting implicit knowledge. The displayed value has no relation to the actual test values and tested SIs

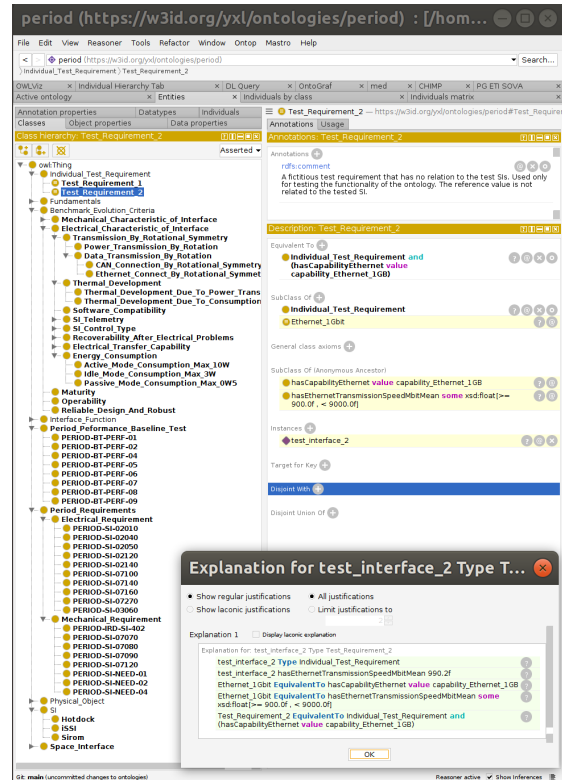

Figure 4: A look at *Period ontology* in the *Protege* environment for ontology development.

lected in the ontology as SI models can be used for other tasks such as mission planning, etc., from various points of view.

## 6. DISCUSSION

Since there is currently no listing of the characteristics of an SI in the form of a benchmark, and TRA cannot serve as a method for advancing technologies, and also requires fixed performance requirements and definition of the operating environment that are outside the scope of the current project. We also noticed that although the SIs all have the same TRL, the method used was not the same and the results were difficult to compare. Therefore, the development of a benchmark was necessary. Based on our results, we found that each interface has its own specific characteristics that are not directly comparable and can play an important role depending on the application. Hence, we have developed generic test cases in the electrical domain that determine the data and power transfer of the test, which are practical and repeatable in the laboratory environment. These are also represented as a generic model for the mechatronic level of an interface in a unified ontology. It was important to consider the test boundaries, which change depending on the characteristics of the interface. Thus, the connection of

test object, test method, and test result was essential. The ontology was a way to model the interface, test steps, and test result in a unified and rich way, and to share them in a way that allowed comparing interfaces based on specific properties and tasks. The general problem was to link the test method, test object, and result in the ontology and integrate them into a workflow in a *Python* environment that automatically interacts with *Owlready* to manage deployment. Thus, we have reached the point that this knowledge about the decision can be used for other purposes (e.g., controlling robots). The offline manual use of knowledge collection (evolution criteria) and the online integrated and automated use of the ontology for generic model creation, storage and standardized data exchange is verified in this work. The use of korcut and its partial domain extension *period ontology* is thus tested in the area of space interfaces in the context of the real hardware task.

## 7. CONCLUSION

In this paper the developed PERIOD benchmark electrical test method to distinguish the SIs was introduced. The test is a four-step process that introduces the SI electrical specification for functional, data and power line characters, which are structured according to application-oriented ontology based 12 criteria. To create the meta-model of the generic interface and share the test results of the SIs in a consistent way. A *period ontology* as part of the korcut was created. The approach for developing the electrical tests from the SIs makes it possible to make a recommendation at the end for one of the three tested SIs, HOTDOCK, iSSI@ or SIROM for use in the PERIOD demonstration scenario. These tests can be further developed and later applied as a standardized basis for selection procedures for multifunctional interconnects that can be used in orbital robotics. Most importantly, it can be used for the development of standards within the European Operation Framework.

## ACKNOWLEDGEMENTS

This work has been carried out within the project PERIOD, which is funded by the European Union within the frame of the Horizon 2020 research and innovation programme under grant agreement No 101004151. The PERIOD consortium consists of Airbus Defence and Space GmbH (Germany), Airbus Defence and Space SAS (France), Airbus Defence and Space Ltd. (UK), GMV Aerospace and Defence S.A.U. (Spain), GMVIS Skysoft S.A. (Portugal), Space Applications Services NV (Belgium), SENER Aerospacial S.A. (Spain), DFKI GmbH (Germany), EASN Technology Innovation Services

BVBA (Belgium), and ISISPACE B.V. (Netherlands).

## BIBLIOGRAPHY

- [1] Xiu-Tian Yan, Wiebke Brinkmann, Roberto Palazzetti, Craig Melville, Youhua Li, Sebastian Bartsch, and Frank Kirchner. Integrated mechanical, thermal, data and power transfer interfaces for future space robotics. *Frontiers in Robotics and AI*, 5:64, 2018.
- [2] Pierre Letier, Torsten Siedel, Mathieu Deremetz, Edrags Pavlovskis, Benoit Lietaer, Korbinian Nottensteiner, Maximo Alejandro Roa Garzon, Juan Sanchez Garcia, Javier Luis Corella, and Jeremi Gancet. Hotdock: Design and validation of a new generation of standard robotic interface for on-orbit servicing. In *International Astronautical Congress, IAC 2020.*, 2020.
- [3] Thomas A. Schervan, Joerg Kreisel, K. U. Schroeder, and D. R. Wingo. New horizons for space exploration via flexible concepts based on building blocks using the standardized issi (intelligent space system interface) modular coupling kit by iboss. In *Global Space Exploration Conference, GLEX2021, IAF*, 2021.
- [4] Montserrat Díaz-Carrasco, Pablo Bedialauneta, Javier Vinals, Jose Gala, and Gonzalo Guerra. Standard interface for robotic manipulation (sirom): Current state and future developments for one of the main building blocks for space robotics advancement. In *72nd International Astronautical Congress (IAC)*, 2021.
- [5] Stephane. Estable et al. Period – peraspera in-orbit demonstration toward the transition into the in-space services, assembly and manufacturing paradigm. In *IOP Conference Series: Materials Science and Engineering*, volume 1, pages 1–8. IOP Publishing, Feb. 2022.
- [6] Marc Manz et. al. Robotic architecture and operational concept for in-space assembly and servicing missions. In *16th Symposium on Advanced Space Technologies in Robotics and Automation (ASTRA)*. European Space Agency, 2022.
- [7] Wiebke Brinkmann et al. Preliminary definition of a standard interconnect benchmark for on-orbit servicing demonstrator. In *Stardust-R - Second Global Virtual Workshop, Munich, Germany*, Sep. 16, 2021.
- [8] Mehmed Yüksel. Korcut ontology family on Zenodo, 2021. <https://doi.org/10.5281/zenodo.4457870>, Accessed: 2021-03-20.

- [9] Jean-Baptiste Lamy. Owlready: Ontology-oriented programming in python with automatic classification and high level constructs for biomedical ontologies. *Artificial Intelligence in Medicine*, 80:11–28, 2017. <https://www.sciencedirect.com/science/article/pii/S0933365717300271>, Accessed: 2021-03-22.
- [10] Marko Jankovic, Mehmed Yüksel, Mohammad Mohammadzadeh Babr, Francesca Letizia, and Vitali Braun. Space debris ontology for adr capture methods selection. *Acta Astronautica*, 173:56 – 68, 2020. <http://www.sciencedirect.com/science/article/pii/S0094576520301752>, Accessed: 2021-03-22.
- [11] Natalya F. Noy and Deborah L. McGuinness. Ontology development 101: A guide to creating your first ontology. Technical report, 2001.
- [12] Antonio De Nicola, Michele Missikoff, and Roberto Navigli. A software engineering approach to ontology building, 2009.
- [13] Mehmed Yüksel. Robotic cars for the future. *CAN Newsletter Hardware + Software + Tools + Engineering*, 2016-4:4–6, 12 2016. <https://tinyurl.com/future-robotic-cars>, Accessed: 2022-04-15.
- [14] Mark A. Musen. The protégé project: A look back and a look forward. *AI Matters*, 1(4):4–12, June 2015. <https://doi.org/10.1145/2757001.2757003>, Accessed: 2021-03-22.